

LT15A

Spare parts

Ersatzteile

Pièces détachées

Reserve onderdelen

Repuestos

Reservdelar

REPAIR PARTS

TRACTOR - MODEL NO. LT15A (J15H42H), PRODUCT NO. 954 13 00-37

ELECTRICAL

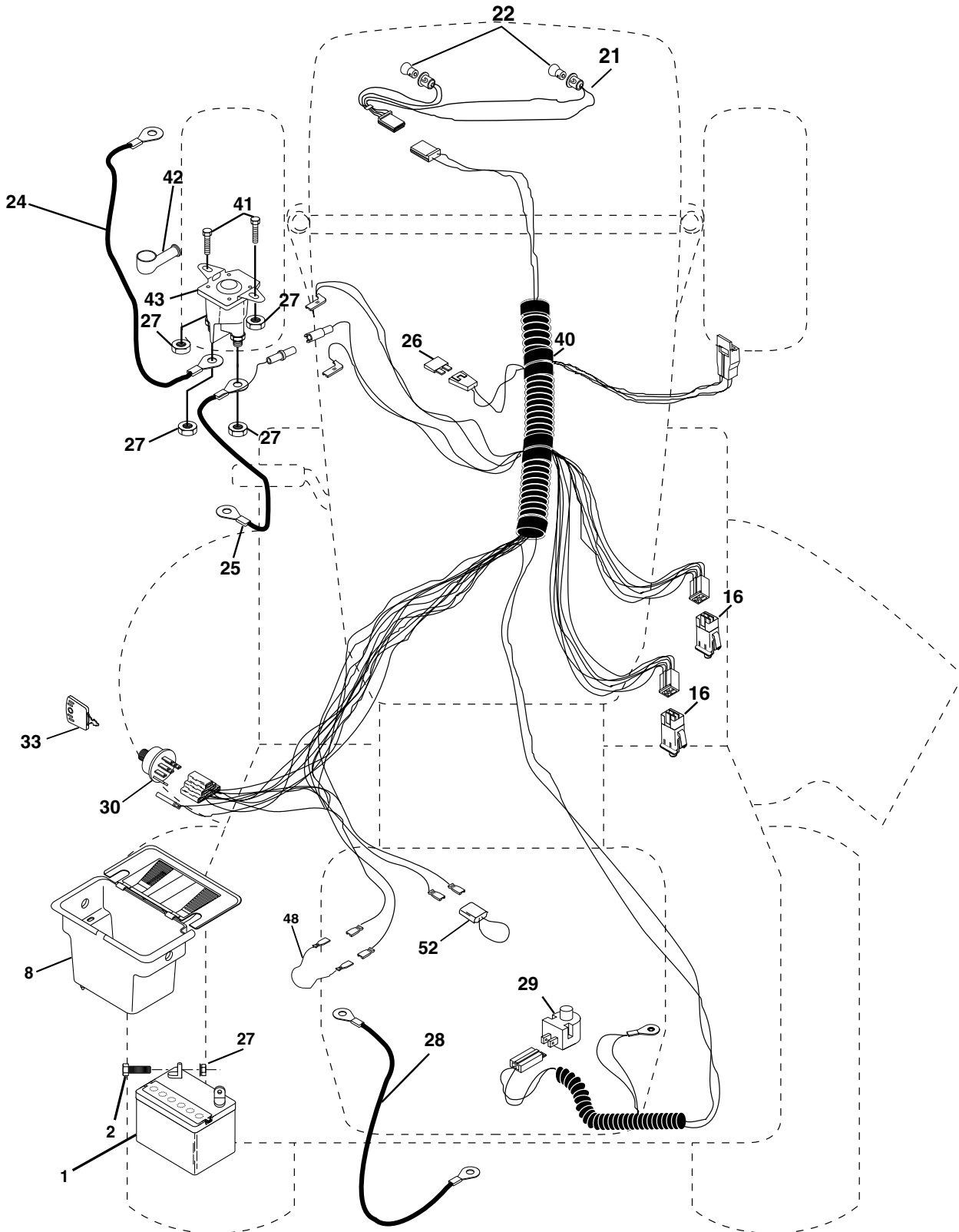

REPAIR PARTS

TRACTOR - MODEL NO. LT15A (J15H42H), PRODUCT NO. 954 13 00-37

ELECTRICAL

KEY NO.	PART NO.	DESCRIPTION
1	532144925	Battery 12 Volt 25 AMP
2	874760412	Bolt Hex Hd 1/4-20unc X 3/4
8	532156417	Case Battery Mech Hinge
16	532153664	Switch Interlock Push-In
21	532166182	Harness Asm Light W/4152j
22	532004152	Bulb Light #1156
24	532124780	Cable Battery 6 Ga 11" red
25	532146147	Cable Battery 6 Ga 44" red w/16 wire
26	532175158	Fuse
27	873510400	Nut Keps Hex 1/4-20 Unc
28	532124773	Cable Ground 6 Ga 12" black
29	532121305	Switch Plunger Nc Gray
30	532175566	Switch Ign
33	532140401	Key Ign Molded Generic
40	532170217	Harness Ign.
41	871110408	Bolt Blk Fin Hex 1/4 - 20 x 1/2
42	532131563	Cover Terminal Red
43	532175141	Solenoid
48	532140844	Adapter Ammeter Rectangular
52	532141940	Protection Wire Loop

NOTE: All component dimensions given in U.S. inches.
1 inch = 25.4 mm.

REPAIR PARTS

TRACTOR - MODEL NO. LT15A (J15H42H), PRODUCT NO. 954 13 00-37

CHASSIS AND ENCLOSURES

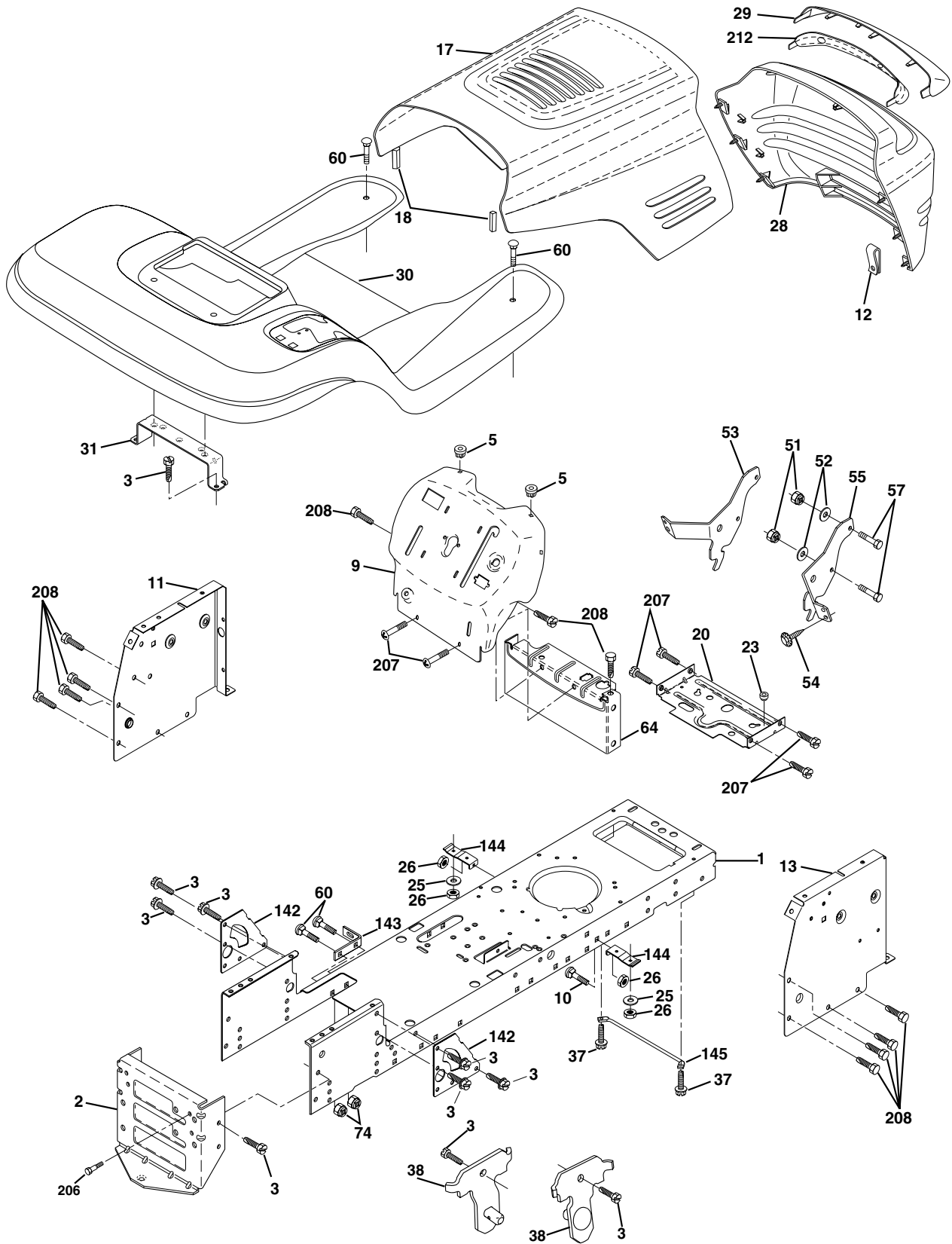

REPAIR PARTS

TRACTOR - MODEL NO. LT15A (J15H42H), PRODUCT NO. 954 13 00-37 CHASSIS AND ENCLOSURES

KEY NO.	PART NO.	DESCRIPTION
1	532169830	Chassis
2	532169061	Drawbar
3	817060612	Screw 3/8-16x3/4
5	532155272	Bumper Hood/Dash
9	532172151	Dash P/L
10	872140608	Bolt Carriage 3/8-16 x 1
11	532155927	Panel Dash Lh
12	532145660	Clip Tinnerman Grille P/L
13	532172108	Panel Dash Rh
17	532150760	Hood LT/PL with Louvers
18	532126938	Bumper Hood
20	532156437	Plate Mtg Battery Fuel Tank Fr
23	532124028	Bushing
25	819131312	Washer 13/32 X 13/16 X 12 Ga
26	873800600	Nut Lock Hex W/Ins 3/8-16 Unc
28	532169509	Grille/Lens Asm
29	532166603	Lens LT/PL Grille Shark Plain
30	532172157	Fender Footrest
31	532139976	Bracket Support Fender
37	817490508	Screw Thdrol 6/16-18 x 1/2 TYT
38	532169834	Bracket Asm Pivot Mower Rear
51	873800400	Nut Lock Hex W/Ins 1/4-20
52	819091416	Washer 9/32 x 7/8 x 16 Ga.
53	532145201	Bracket Pnt. Pickoff LH
54	532161464	Screw Hex Wshd 8-18 x 7/8
55	532145202	Bracket Grille Pickoff RH
57	874780412	Bolt Hex 1/4-20 x 3/4
60	872140606	Bolt Rdhd Sqnk 3/8-16unc x 3/4
64	532154798	Dash Lower STLT
74	873680600	Nut Crownlock 3/8-16 UNC
142	532165867	Plate Reinforcement STLT
143	532154966	Bracket Swaybar Chassis
144	532154207	Bracket Pnt Footrest STLT
145	532156524	Rod Pivot Chassis/Hood
206	532170165	Bolt Shoulder 5/16-18 TT
207	817670508	Screw Thdrol 5/16-18 x 1/2 TY TT
208	817670608	Screw Thdrol 3/8-16 x 1/2 TY TT
212	532165919	Insert Lens Reflective
--	532005479	Plug Button

NOTE: All component dimensions given in U.S. inches
1 inch = 25.4 mm

REPAIR PARTS

TRACTOR - MODEL NO. LT15A (J15H42H), PRODUCT NO. 954 13 00-37

DRIVE

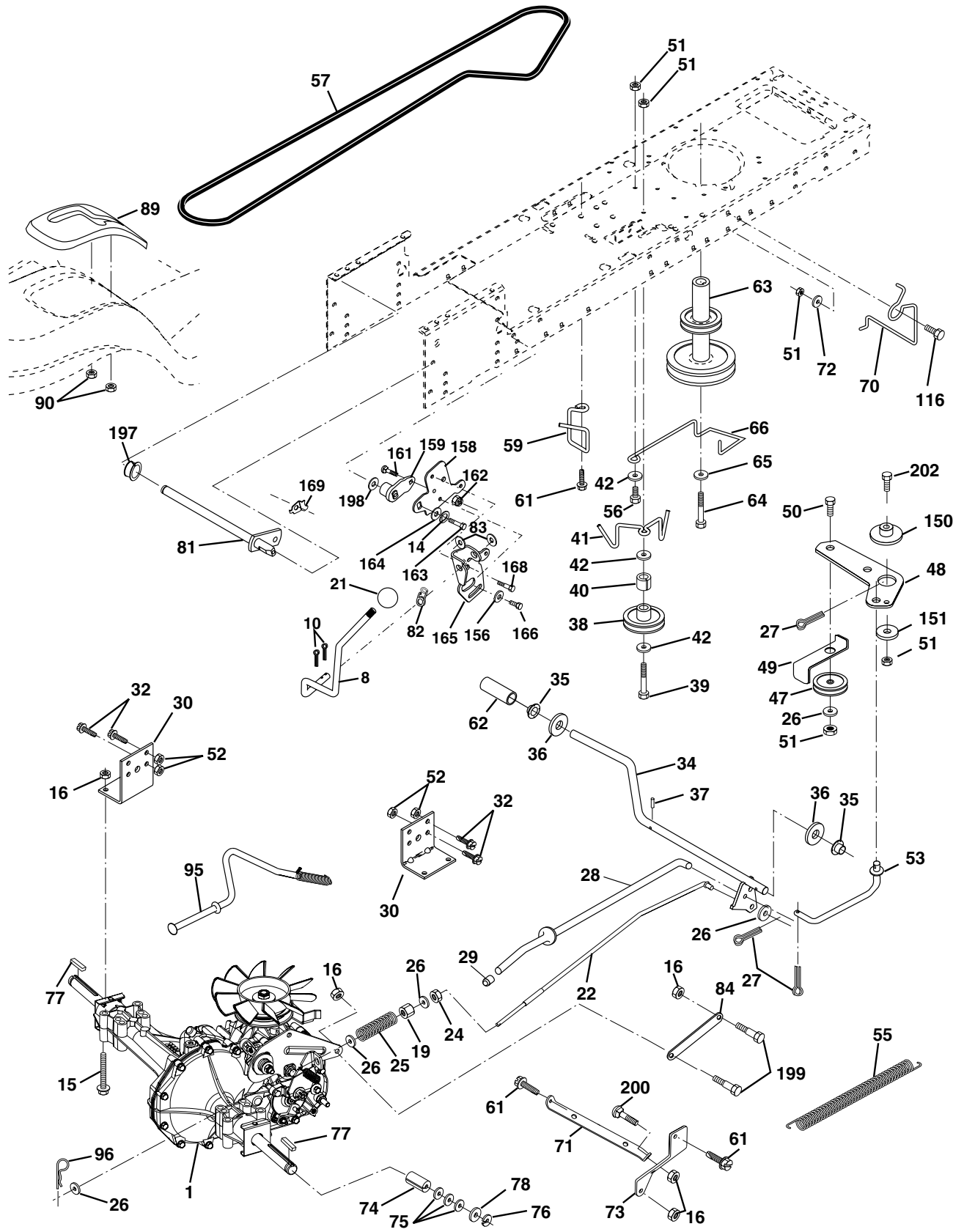

REPAIR PARTS

TRACTOR - MODEL NO. LT15A (J15H42H), PRODUCT NO. 954 13 00-37

DRIVE

KEY NO.	PART NO.	DESCRIPTION	KEY NO.	PART NO.	DESCRIPTION
1	-----	Transaxle Hydro Gear 314-0510 Order parts from transaxle manufacturer	64	871170764	Bolt, Hex
8	532165866	Rod Shift Fender Adjust Lt	65	810040700	Washer
10	876020416	Pin Cotter 1/8 x 1 CAD	66	532154778	Keeper Belt Engine
14	810040400	Washer Lock Hvy Helical	70	532134683	Keeper Belt Engine
15	874490544	Bolt Fin Hex 5/16-18 x Gr. 5	71	532169183	Strap Torque Lh Hydro
19	873800600	Nut Lock Hex W/Wsh 3/8-16 Unc	72	819132012	Washer 13/32 x 1-1/4 x 12 Gauge
21	532130564	Knob 1/2-13	73	532169182	Strap Torque Rh Hydro
22	532169498	Rod, Brake Hydro	74	532137057	Spacer, Axle
24	873350600	Nut	75	532121749	Washer 25/32 x 1-1/4 x 16 Gauge
25	532106888	Spring, Brake Rod	76	812000001	E-Ring
26	819131316	Washer	77	532123583	Key, Square
27	876020412	Pin Cotter 1/8 x 3/4 CAD.	78	532121748	Washer 25/32 x 1-5/8 x 16 Gauge
28	532145204	Rod, Parking Brake	81	532165596	Shaft Asm. Cross Tapered
29	532071673	Cap, Parking Brake	82	532165711	Spring Torsion T/A
30	532169592	Bracket, Transaxle	83	819171216	Washer 17/32 x 3/4 x 16 Ga.
32	874760512	Bolt Hex Hd 5/16-18 Unc x 3/4	84	532169594	Link Transaxle
34	532155071	Shaft, Foot Pedal	89	532166602	Console, Shift
35	532120183	Bearing, Nylon	90	532124346	Nut Self-thd Wsh-hd 1/4 Zinc
36	819211616	Washer	95	532170201	Control Asm Bypass Hydro
37	532124963	Pin, Roll	96	532124788	Retainer Spring 1" Zinc/Cad
38	532131494	Pulley, Idler, Flat	116	872110610	Bolt Rdhd Sq Neck 3/8-16 x 1.25
39	874760644	Bolt	150	532165850	Bushing Bellcrank Grd Drive
40	532124965	Spacer, Split	151	819133210	Washer 13/32 x 2 10 Ga.
41	532165838	Keeper, Belt Idler	156	532166002	Washer Srrted 5/16 ID x 1.125
42	819131312	Washer 13/32 x 13/16 x 12 Gauge	158	532165589	Bracket Shift Mount
47	532127783	Pulley, Idler, V-Groove	159	532165494	Hub Tapered Flange Shift Lt
48	532154407	Bellcrank Clutch Grnd Drv STL	161	872140406	Bolt Rdhd Sqnk 1/4-20 x 3/4 Gr 5
49	532123205	Retainer, Belt	162	873680400	Nut Crownlock 1/4-20 Unc
50	874760624	Bolt	163	874780416	Bolt Hex Fin 1/4-20 Unc x 1 Gr 5
51	873680600	Nut	164	819091010	Washer 5/8 x .281 x 10 Ga
52	873680500	Nut Crownlock 5/16-18 UNC	165	532165623	Bracket Pivot Lever
53	532105710	Link, Clutch	166	532166880	Screw 5/16-18 x 5/8
55	532105709	Spring, Return, Clutch	168	532165492	Bolt Shoulder 5/16-18 x .561
56	874760620	Bolt Fin Hex 3/8-16 x 1-1/4	169	532165580	Plate Fastening Lt
57	532140294	V-Belt, Ground Drive	197	532169613	Nyliner Snap-In 5/8" ID
59	532169691	Keeper, Center Span	198	532169593	Washer Nyl 7/8 ID x .105" Hyd
61	817060612	Screw 3/8-16 x 3/4	199	532169612	Bolt Shoulder 5/16-18 Unc
62	532124872	Cover, Pedal	200	872140508	Bolt Rdhd Sqnk 5/16-18 Unc x 1
63	532140186	Pulley, Engine	202	872110612	Bolt Carr Sh 3/8-16 x 1-1/2

NOTE: All component dimensions given in U.S. inches
1 inch = 25.4 mm

REPAIR PARTS

TRACTOR - MODEL NO. LT15A (J15H42H), PRODUCT NO. 954 13 00-37

STEERING ASSEMBLY

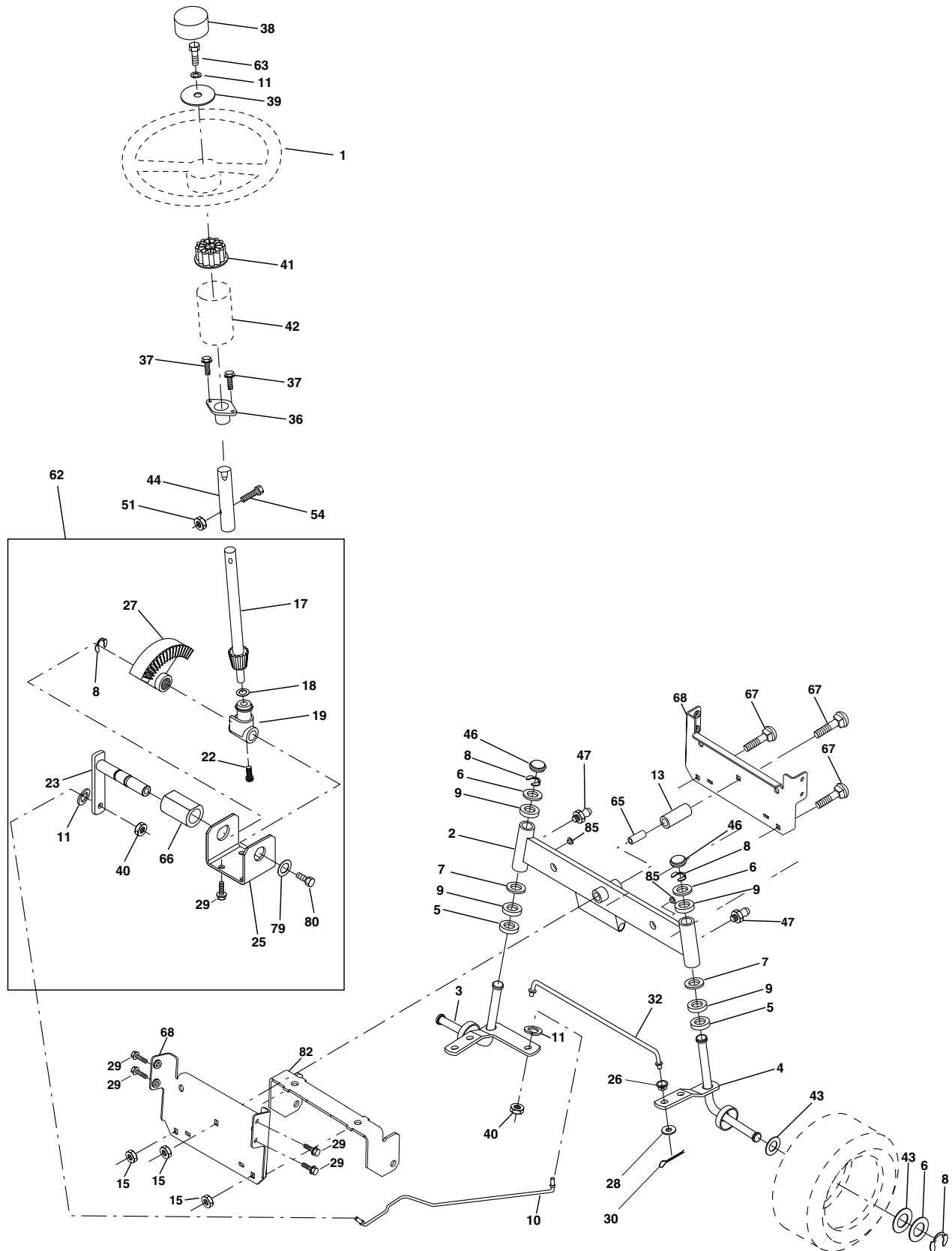

REPAIR PARTS

TRACTOR - MODEL NO. LT15A (J15H42H), PRODUCT NO. 954 13 00-37

STEERING ASSEMBLY

KEY NO.	PART NO.	DESCRIPTION
1	532172092	Wheel Steering
2	532154427	Axle Asm STMP Dropped STL
3	532169840	Spindle Asm LH
4	532169839	Spindle Asm RH
5	532124931	Bearing Race Thrust Harden
6	532121748	Washer 25/32 X 1-5/8 X 16 Ga
7	819272016	Washer 27/32 X 1-1/4 X 16 Ga
8	812000029	Ring Klip #t5304-75
9	532124937	Bearing Col Strg Blk
10	532169832	Link Drag
11	810040600	Washer Lock Hvy Hlcl Spr 3/8
13	532136518	Spacer Brg Axle Front
15	532145212	Nut Hex Flange Lock
17	532156546	Shaft Asm Strg
18	532057079	Washer Thrust 515x 750x 033
19	532160395	Support Shaft
22	532165857	Screw Hex Wsh hd Torx
23	532165851	Shaft Asm Pittman
25	532154406	Bracket Steering
26	532126847	Bushing Link Drag
27	532136874	Gear Sector
28	819131416	Washer 13/32 X 7/8 X 16ga.
29	817060612	Screw 3/8-16x3/4
30	876020412	Pin Cotter 1/8 X 3/4 Cad.
32	532130465	Rod Tie
36	532155099	Bushing Strg
37	532152927	Screw
38	532172093	Insert Cap Strg Wh
39	819132411	Washer 13/32 X 1-1/20 x 11 Ga
40	532124701	Lock nut
41	532159945	Adaptor Wheel Strg
42	532169633	Boot Steering Shaft
43	532121749	Washer 25/32 X 1 1/4 X 16 Ga
44	532153720	Extension Steering Shaft LR/LT
46	532121232	Cap Spindle Fr Top Blk
47	532124836	Fitting Grease
51	873800500	Nut Lock Hex w/Ins 5/16-18
54	874780520	Bolt Fin Hex 5/16-18 Unc x 1-1/4
62	532167902	Kit, Steering Assembly Svc
63	874780616	Bolt Fin Hex 3/8-16unc x 1 Gr. 5
65	532160367	Spacer Brace Axle
66	532154404	Bearing Arm Pittman
67	872140618	Bolt Rdhd Sq 3/8-16 x 2-1/4
68	532169827	Axle, Brace
79	819132012	Washer 13/32 x 1-1/4 x 12 Ga
80	874950612	Bolt Hex Nylon 3/8-16 x 3/4
82	532169835	Bracket Susp Chassis Front
85	532133835	Fastner Christmas Tree

NOTE: All component dimensions given in U.S. inches.
1 inch = 25.4 mm.

REPAIR PARTS

TRACTOR - MODEL NO. LT15A (J15H42H), PRODUCT NO. 954 13 00-37

ENGINE

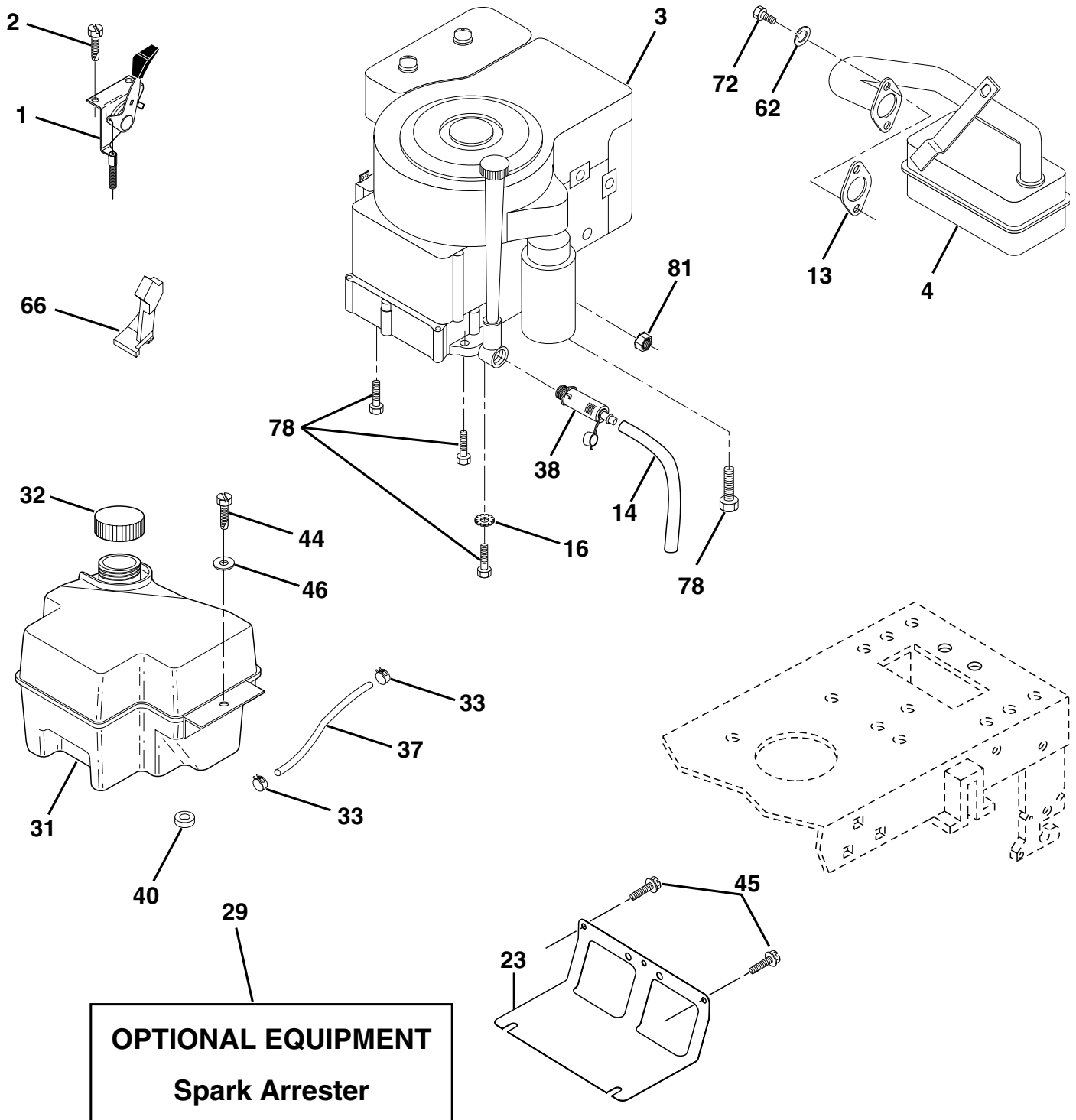

REPAIR PARTS

TRACTOR - MODEL NO. LT15A (J15H42H), PRODUCT NO. 954 13 00-37

ENGINE

KEY NO.	PART NO.	DESCRIPTION
1	532170865	Control Th/ch B&S EEC Flag
2	817720410	Screw Hex Thd Cut 1/4-20 x 5/8 T
3	-----	Engine B&S Model No. 287707 Order parts from engine manufacturer
4	532137352	Muffler LT B&S
13	532165291	Gasket
14	532148456	Tube Drain Oil Easy
16	811050600	Washer Lock Ext Tooth 3/8
23	532169837	Shield Brn/Dbr Guard
29	532137180	Kit Spark Arrestor (Flat Scrn)
31	532174642	Tank Fuel Front 2 00
32	532140527	Cap Asm Fuel W/sym Vented
33	532123487	Clamp Hose Black
37	532137040	Line Fuel 20"
38	532148315	Plug Drain Oil Easy
40	532124028	Bushing Snap Nyl Blk Fuel Line
44	817670412	Screw Hexwsh Thdrol 1/4-20x3/4
45	817000612	Screw Hexwsh 3/8-16 x 3/4
46	819091416	Washer 9/32 X 7/8 X 16 Ga
62	810040500	Washer Lock Hvy Hlcl Spr 5/16
66	532127951	Stop Throttle 3000 RPM
72	871070512	Screw Hexhd Cap 5/16-18x 3/4
78	817060620	Screw 3/8-16 x1-1/4
81	873510400	Nut Keps Hex 1/4-20 nc

NOTE: All component dimensions given in U.S. inches
1 inch = 25.4 mm

REPAIR PARTS

TRACTOR - MODEL NO. LT15A (J15H42H), PRODUCT NO. 954 13 00-37

SEAT ASSEMBLY

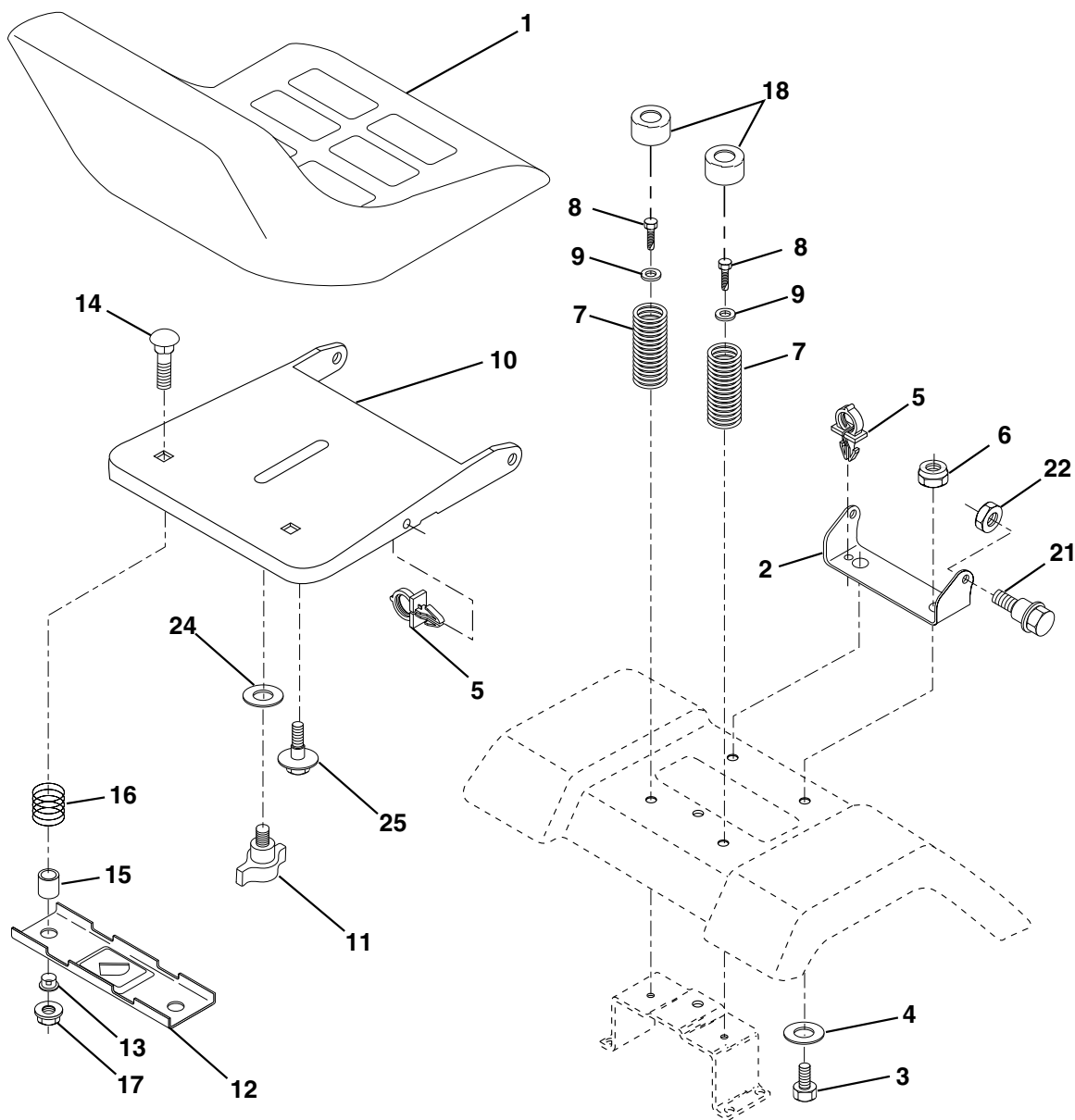

KEY NO.	PART NO.	DESCRIPTION
1	532140117	Seat
2	532140551	Bracket Pivot Seat 8 720
3	871110616	Bolt Fin Hex 3/8-16unc X 1
4	819131610	Washer 13/32 X 1 X 10 Ga
5	532145006	Clip Push-In
6	873800600	Nut Hex w/Ins. 3/8-16 Unc
7	532124181	Spring Seat Cprsn 2 250 Blk Zi
8	817000616	Screw 3/8-16 X 1-1/2
9	819131614	Washer 13/32 X 1 X 14 Ga.
10	532174894	Pan Seat
11	532166369	Knob Seat
12	532121246	Bracket Mounting Switch

KEY NO.	PART NO.	DESCRIPTION
13	532121248	Bushing Snap Blk Nyl 50 Id
14	872050412	Bolt Rdhd Sqkn 1/4-20x1-1/2
15	532134300	Spacer Split 28x96 Yel Zinc
16	532121250	Spring Cprsn 1 327 Blk Pnt
17	532123976	Nut Lock 1/4 Lge Flg Gr 5 Zinc
18	532124238	Cap Spring Seat
21	532171852	Bolt Shoulder 5/16-18 Unc
22	873800500	Nut Hex Lock W/Ins 5/16-18
24	819171912	Washer 17/32 X 1-3/16 X 12 Ga.
25	532127018	Bolt Shoulder 5/16-18 X 62

NOTE: All component dimensions given in U.S. inches.
1 inch = 25.4 mm

REPAIR PARTS

TRACTOR - MODEL NO. LT15A (J15H42H), PRODUCT NO. 954 13 00-37

DECALS

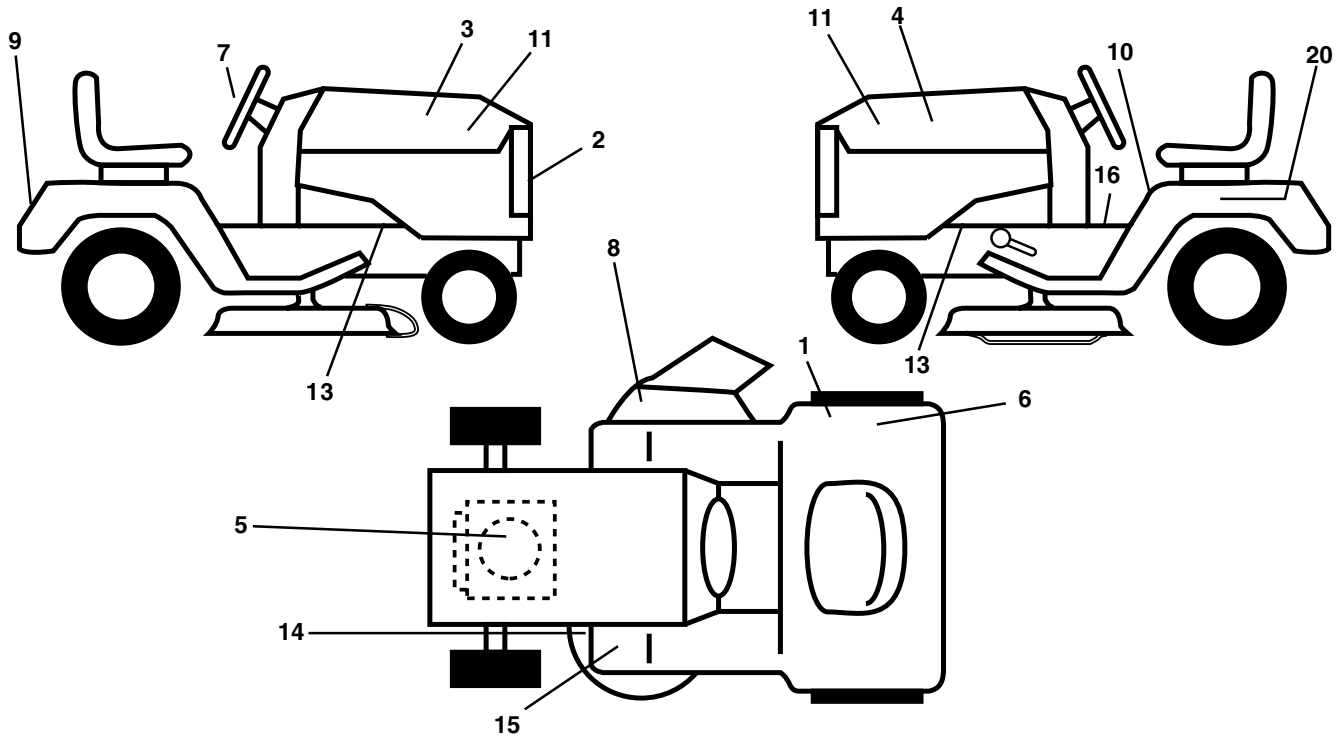

KEY NO.	PART NO.	DESCRIPTION
1	532126187	Decal 100 DBA
2	532152262	Decal Grille Jonsered Sweden
3	532170704	Decal Hood RH
4	532170705	Decal Hood LH
5	532170846	Decal HP Engine
6	532145437	Decal Europe Stand CE
7	532170565	Decal, Ins. Strg Whl. Jons.
8	532145494	Decal Mower Cutfinger
9	532141761	Decal Fender Jonsered
10	532145498	Decal Read Owner's Manual Syms.
11	532162927	Decal Hood Insert

KEY NO.	PART NO.	DESCRIPTION
13	532159736	Decal Chassis Hot Muffler
14	532160396	Decal V-Belt Schematic
15	532159737	Decal Brake/Clutch Symbol Lt
16	532140837	Decal Saddle Brake Parking
20	532145005	Decal Bat Dan/Psn
--	532171284	Pad Footrest LH STLT
--	532171285	Pad Footrest RH STLT
--	532138311	Decal Handle Lift Height Adjust
--	532169210	Decal By Pass Lt Hydro
--	532162598	Decal Drawbar Load Limit
--	532176853	Manual Operator's (Euro.)
--	532176854	Manual Operator's (Scan.)

WHEELS & TIRES

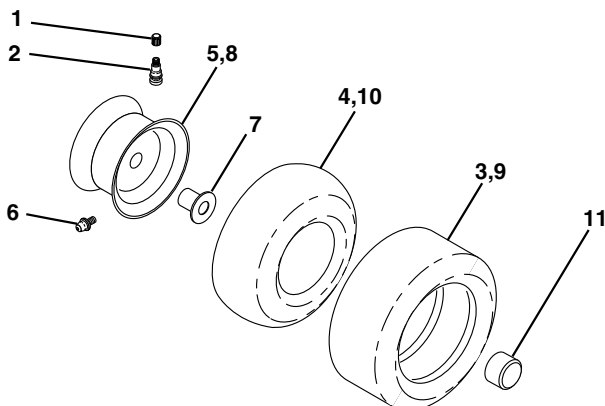

KEY NO.	PART NO.	DESCRIPTION
1	532059192	Cap Valve Tire
2	532065139	Stem Valve
3	532106222	Tire F Ts 15 X 6 0 - 6 Service
4	532059904	Tube Front (Service Item Only)
5	532138336	Rim Asm 6"front Silver Service
6	532124957	Fitting Grease (Front Wheel Only)
7	532124959	Bearing Flange (Front Wheel Only)
8	532138337	Rim Asm 8"rear Silver Service
9	532122082	Tire R Ts 20x10-8 C Service
10	532124926	Tube Rear (Service Item Only)
11	532175039	Cap Axle Blk 1 50 X 1 00
--	532144334	Sealant, Tire (10 oz. Tube)

NOTE: All component dimensions given in U.S. inches
1 inch = 25.4 mm

REPAIR PARTS

TRACTOR - MODEL NO. LT15A (J15H42H), PRODUCT NO. 954 13 00-37

MOWER DECK

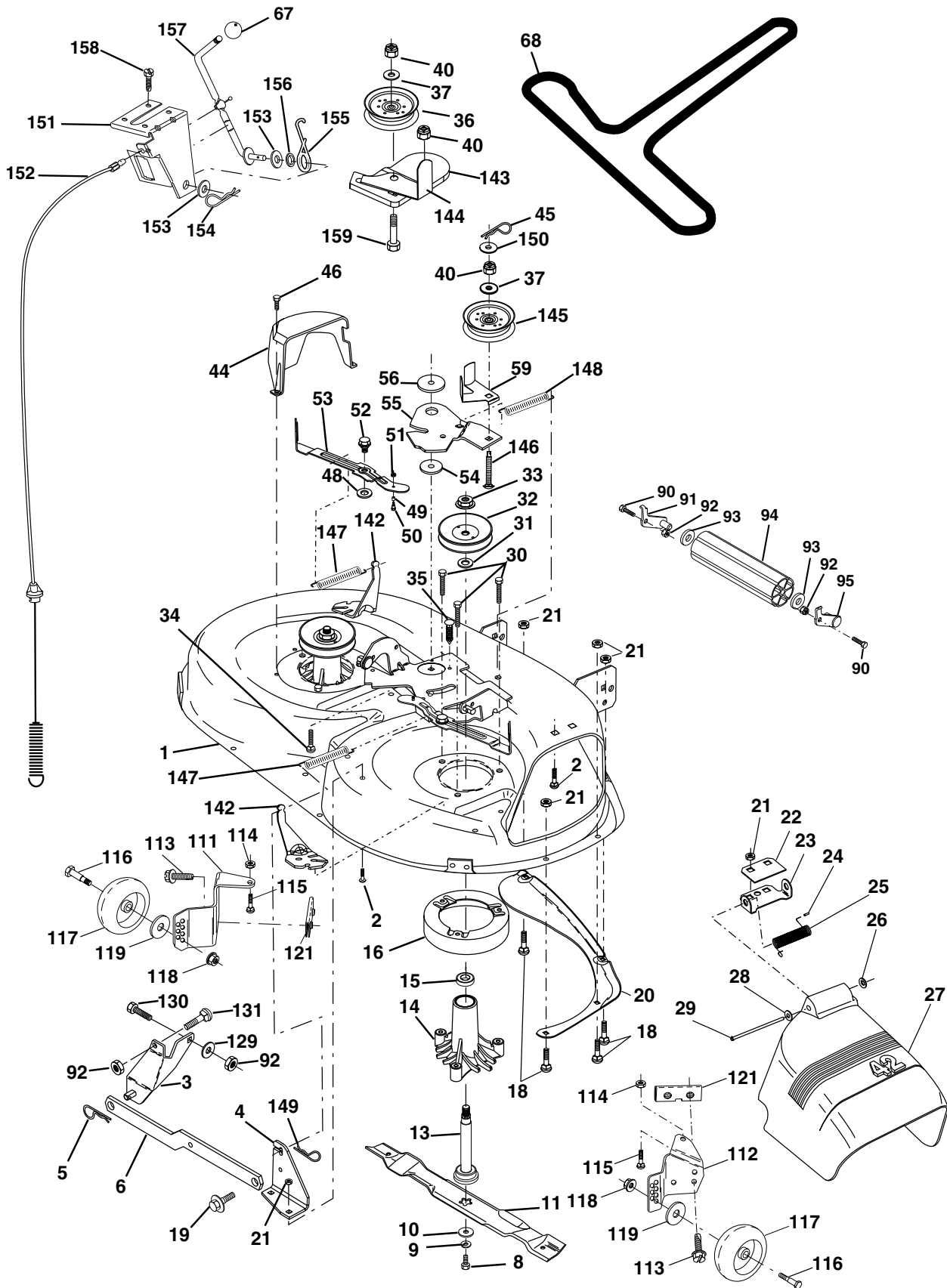

REPAIR PARTS

TRACTOR - MODEL NO. LT15A (J15H42H), PRODUCT NO. 954 13 00-37

MOWER DECK

KEY NO.	PART NO.	DESCRIPTION	KEY NO.	PART NO.	DESCRIPTION
1	532165892	Housing Asm Mower	67	532106932	Knob Rd 3/8-16 Plstc Thds Blk
2	872140506	Bolt Rdhd Sqnk 5/16-18unc X3/4	68	532144959	V-Belt Mower
3	532138017	Bracket Asm Fr Sway Bar 38/42	90	874760616	Bolt Fin Hex 3/8-16unc X 1
4	532165460	Bracket Asm Deck 42"sway Bar	91	532132274	Bracket Asm Noseroller LH
5	532124670	Retainer Spring	92	873800600	Nut Lock Hex w/ins. 3/8-16 UNC
6	532130832	Arm Suspension Rear	93	819171416	Washer 17/32 X 7/8 X 16 Ga
8	532850857	Bolt 3/8-24x1 25 Gr8 Patched	94	532132264	Roller Nose 38 & 42
9	810030600	Washer Lock Hvy 3/8 Unplated	95	532132273	Bracket Asm Noseroller RH
10	532140296	Washer Hard Blade Mower Vented	111	532155197	Bracket Gauge Wheel Lh
11	532138498	Blade Mower High Lift"	112	532155198	Bracket Gauge Wheel Rh
13	532137645	Shaft Asm W/lower Bearing	113	817060514	Screw Tapping 5/16-18 Unc
14	532128774	Housing Mandrel Vented(machd)	114	873510500	Nut Keps 5/16-18 UNC
15	532110485	Bearing Ball Mandrel	115	872110504	Bolt Carriage 5/16-18unc x 1/2
16	532140329	Stripper Round Mower	116	532124842	Bolt Shoulder
18	872140505	Bolt Carr 5/16-18 X 5/8	117	532165746	Wheel Gauge
19	532132827	Bolt Shoulder	118	873930600	Nut Centerlock 3/8-16 UNC
20	532159770	Baffle Vortex	119	819121414	Washer 3/8 x 7/8 x 14 Ga.
21	873680500	Nut Crown Lock 5/16-18	121	532143723	Bracket Extruded Gauge Wheel
22	532134753	Stiffener Bracket 42"deck	129	819131312	Washer 13/32 x 13/16 x 12 Ga.
23	532131267	Bracket Deflector Mower 42"	130	874780616	Bolt Fin Hex 3/8-16 UNC x 1 Gr. 5
24	532105304	Cap Sleeve 80x 112 Blk Mower	131	872140608	Bolt Rdhd Sqnk 3/8-16 x 1
25	532123713	Spring Torsion Deflector 2 52	142	532165890	Arm Spring Brake Mower
26	532110452	Nut Push Phos & Oil	143	532157109	Bracket Arm Idler 42"
27	532171859	Shield Deflector	144	532158634	Keeper Belt 42" Clutch Cable
28	819111016	Washer 11/32 X 5/8 X 16 Ga	145	532165888	Pulley Idler Flat
29	532131491	Rod Hinge 42"6 75 Wlg	146	532171977	Bolt Carriage Idler
30	532157722	Screw Thdrol Washer Head	147	532131335	Spring Extension
31	532129963	Washer Spacer Mower Vented	148	532169022	Spring Return Idler
32	532153535	Pulley Mandrel	149	532165898	Retainer Spring Yellow
33	532137266	Nut 9/16top Lock Flng Cntr	150	819091216	Washer 9/32 x 3/4 x 16 Ga.
34	872110614	Bolt RDHD 3/8-16 UNC x 2-3/4 Gr.5	151	532169670	Bracket Clutch Cable
35	532133835	Fastner Christmas Tree	152	532169676	Clutch Cable 42"
36	532131494	Pulley Idler Flat 3 060	153	532169674	Washer Flat 3/8" Type B
37	819131316	Washer 13/32 X 13/16 X 16 Ga	154	532169675	Spring Retainer
40	873680600	Nut Lock 3/8-16 Unc	155	532169671	Spring Retention Lvr Cltch Cab
44	532140088	Guard Mandrel LH Black	156	532169672	Spacer Clutch Cable
45	532124788	Spring Retainer 1" Zinc/cad	157	532169669	Rod Clutch Cable 3/8"
46	532137729	Screw Thdrol 1/4-20x5/8	158	817720410	Screw Hex Thd Cut 1/4-20 x 5/8
48	532133944	Washer Hardened Samllr	159	872140614	Bolt Rdhd Sqn 3/8-16 Unc x 1-3/4
49	532174284	Roller Asm Cam Follower 42" dec	--	532171491	Deck Serv 42" (Standard Deck - Order Nose Roller, Gauge Wheel and Mulcher Plate components separately Key Nos. 90-95, 101-106 and 111-121)
50	532131340	Bolt Shldr 10-24 Zinc Gr 5 42"			
51	532069180	Nut Lock #10-24 Unc			
52	532139888	Bolt Shoulder 5/16-18 Unc Blkz			
53	532131845	Arm Asm Pad Brake			
54	532133943	Washer Hardened	--	532130794	Mandrel Assembly (Includes Key Numbers 8-10, 12-15, 31 and 33)
55	532155046	Arm Idler 42"mower LT/YT			
56	532165723	Spacer Retainer Mower			
59	532141043	Guard, Belt			

NOTE: All component dimensions given in U.S. inches
1 inch = 25.4 mm

REPAIR PARTS

TRACTOR - MODEL NO. LT15A (J15H42H), PRODUCT NO. 954 13 00-37
MOWER LIFT

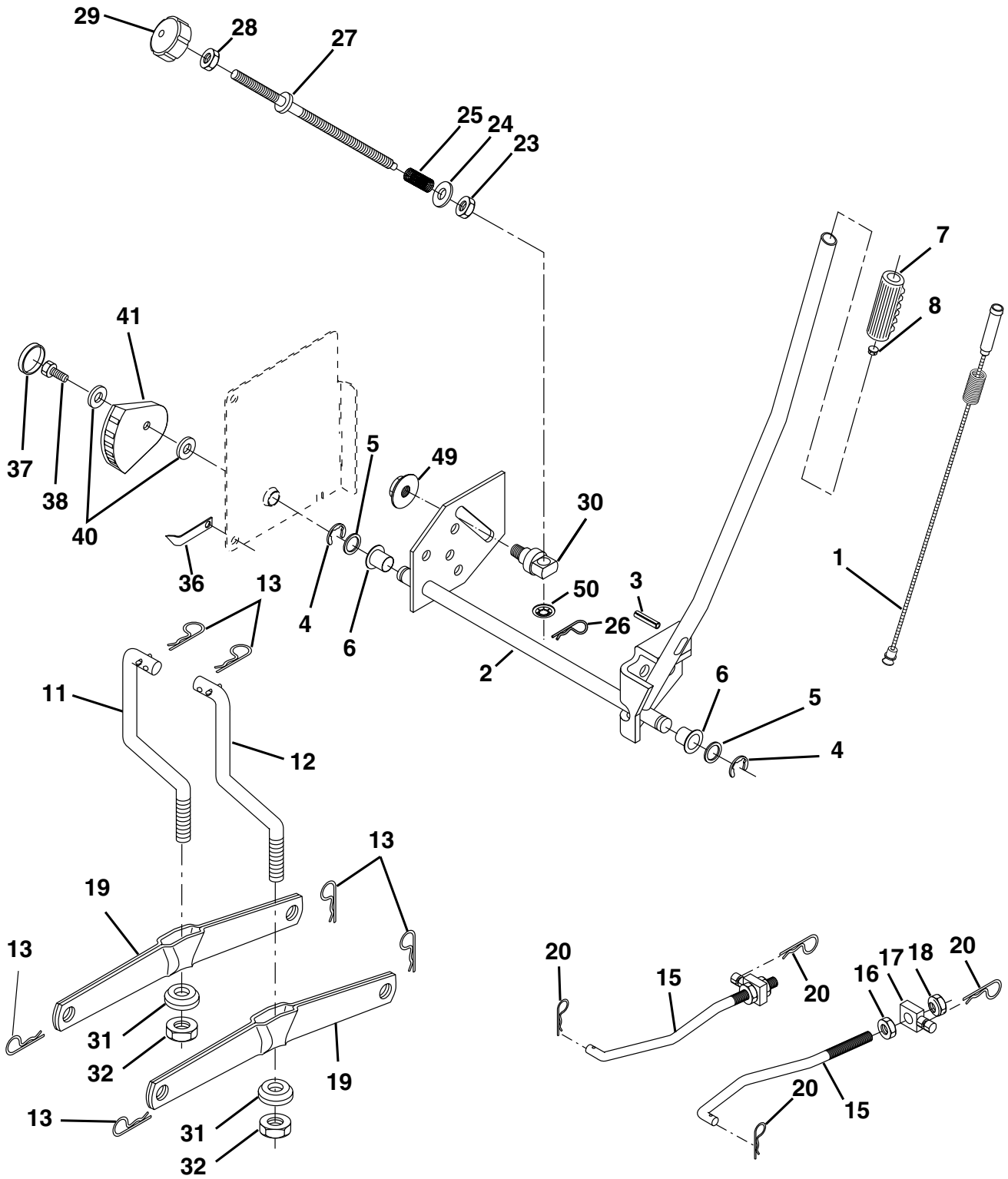

REPAIR PARTS

TRACTOR - MODEL NO. LT15A (J15H42H), PRODUCT NO. 954 13 00-37

MOWER LIFT

KEY NO.	PART NO.	DESCRIPTION
1	532159460	Wire Asm Inner W/plunger
2	532159471	Shaft Asm Lift RH
3	532105767	Pin Groove 1 500 Zinc
4	812000002	E Ring #5133-62
5	819211621	Washer 21/32 X 1 X 21 Ga
6	532120183	Bearing Nylon Blk 629 Id
7	532125631	Grip Handle Flute Blk.
8	532122365	Button Plunger
11	532139865	Link Lift LH Fixed Length
12	532139866	Link Lift RH Fixed Length
13	532124670	Retainer Spring
15	532173288	Link Front
16	873350800	Nut Jam Hex 1/2-13 Unc
17	532130171	Trunnion Blk Zinc
18	873800800	Nut Lock w/wsh 1/2-13 Unc
19	532139868	Arm Suspension Rear
20	532163552	Retainer Spring
23	532110807	Nut Special
24	819131016	Washer 13/32 X 5/8 X 16 Ga
25	532124874	Spring 2-1/8"
26	532169484	Retainer Clip
27	532126971	Rod Adj Lift Zinc 7.49 Wrk Lg
28	873350600	Nut Hex Jam 3/8-16 Unc
29	532138057	Knob Inf 3/8-16 Unc Blk W/sym
30	532150233	Trunnion Dp Stop Dbl Thds PLT
31	532169865	Bearing Pvt Lift
32	873540600	Nut Crownlock 3/8-24
36	532155097	Pointer Pnt Height ind .505
37	532123935	Plug Hole Blk 1.485/1.515 Dia.
38	817060516	Screw 5/16-18 x 1
40	819112410	Washer 11/32 x 1-1/2 10 Ga.
41	532155098	Scale Ind. Height Blk.
49	532145212	Nut Hex Flange Lock
50	532110452	Nut Push Phos & Oil

NOTE: All component dimensions given in U.S. inches
1 inch = 25.4 mm

TRACTOR - MODEL NO. LT15A (J15H42H), PRODUCT NO. 954 13 00-37

SCHEMATIC

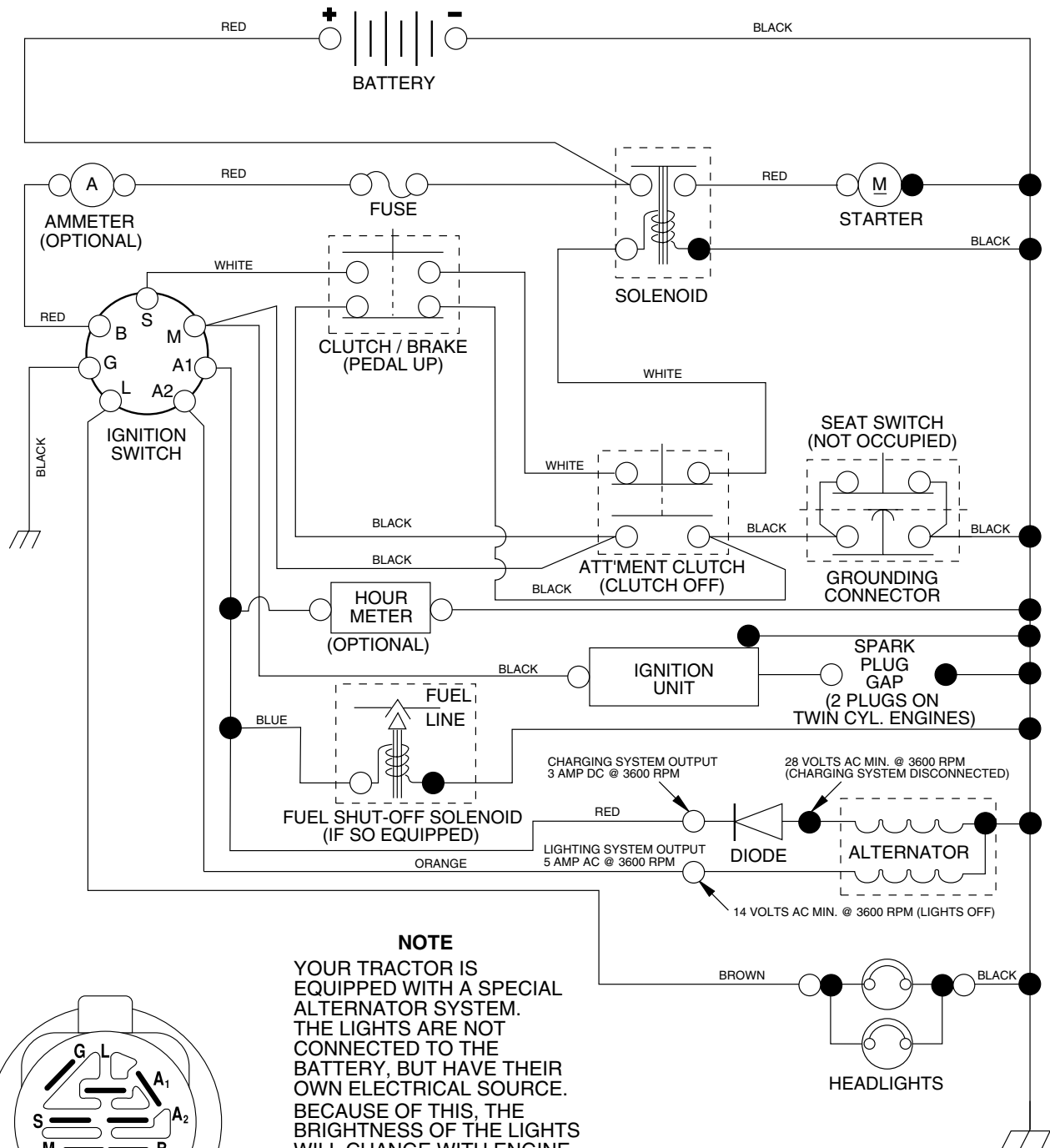

NOTE

YOUR TRACTOR IS EQUIPPED WITH A SPECIAL ALTERNATOR SYSTEM. THE LIGHTS ARE NOT CONNECTED TO THE BATTERY, BUT HAVE THEIR OWN ELECTRICAL SOURCE. BECAUSE OF THIS, THE BRIGHTNESS OF THE LIGHTS WILL CHANGE WITH ENGINE SPEED. AT IDLE THE LIGHTS WILL DIM. AS THE ENGINE IS SPEEDED UP, THE LIGHTS WILL BECOME THEIR BRIGHTEST.

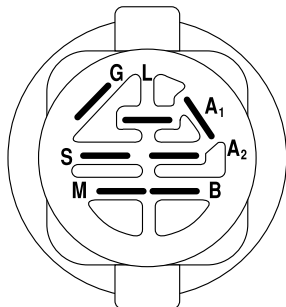

IGNITION SWITCH

POSITION	CIRCUIT	"MAKE"
OFF	M+G+A1	NONE
RUN/LIGHT	B+A1	A2+L
RUN	B+A1	NONE
START	B + S + A1	NONE

WIRING INSULATED CLIPS

NOTE: IF WIRING INSULATED CLIPS WERE REMOVED FOR SERVICING OF UNIT, THEY SHOULD BE REPLACED TO PROPERLY SECURE YOUR WIRING.

NON-REMOVABLE CONNECTIONS

REMOVABLE CONNECTIONS